

MC "DOUBLE-CHANNEL"

Submersible pumps

for sewage water



PERFORMANCE RANGE

- Flow rate up to **800 l/min** (48 m³/h)
- Head up to **15 m**

APPLICATION LIMITS

- **10 m** maximum immersion depth
- Maximum liquid temperature **+40 °C**
- Passage of suspended solids up to **Ø 50 mm**
- **320 mm** minimum immersion depth for continuous service

CONSTRUCTION AND SAFETY STANDARDS

- Complete with **10 m** long power cable
- Float switch for single-phase versions

EN 60034-1
IEC 60034-1
CEI 2-3



CERTIFICATIONS



АН30



УкрТЕСТ-003

INSTALLATION AND USE

MC series pumps, made from heavy gauge cast iron offering exceptional sturdiness, abrasion resistance and durability, come equipped with a DOUBLE-CHANNEL impeller and are capable of pumping liquids containing short fibred suspended solids up to Ø 50 mm.

They are ideal for pumping **sewage, waste water, water mixed with mud, groundwater and surface water** in locations such as apartment blocks, factories, tower garages, underground car parks and cleaning areas, etc.

PATENTS - TRADE MARKS - MODELS

- Registered Community Design n° 342159-0017

OPTIONALS AVAILABLE ON REQUEST

- Single-phase pumps without float switch
- Other voltages or 60 Hz frequency

GUARANTEE

1 year subject to terms and conditions

CHARACTERISTIC CURVES AND PERFORMANCE DATA

50 Hz n= 2900 1/min

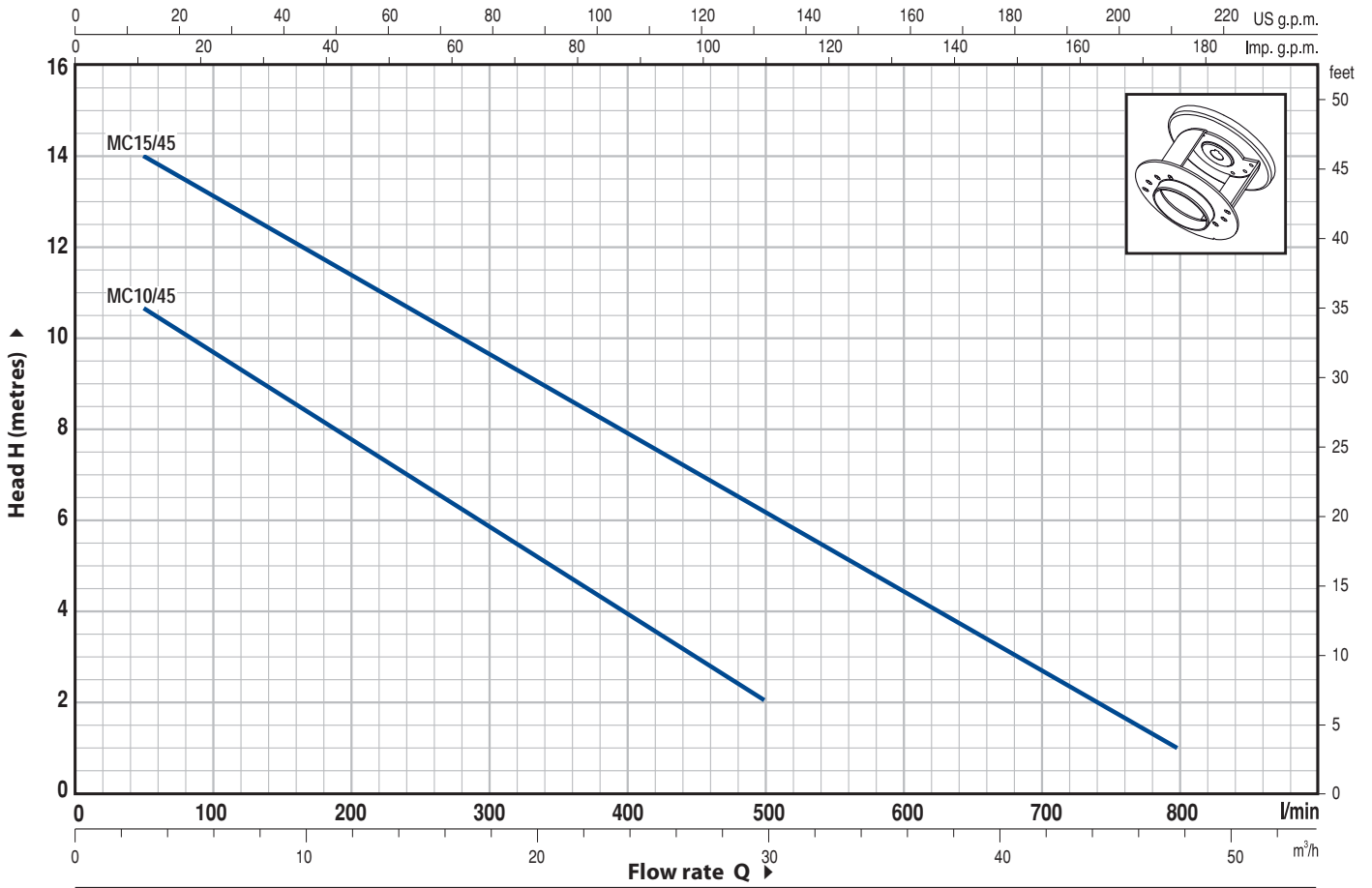

MODEL		POWER		Q	Flow rate															
Single-phase	Three-phase	kW	HP		m³/h	0	3	6	9	12	15	18	21	24	27	30	36	42	48	
MCm 10/45	MC 10/45	0.75	1	l/min	0	50	100	150	200	250	300	350	400	450	500	600	700	800		
MCm 15/45	MC 15/45	1.1	1.5	H metres	12	10.7	9.7	8.7	7.8	6.8	5.9	5	4	3	2					
					15	14	13	12.3	11.5	10.5	9.7	8.8	8	7	6.2	4.5	2.7	1		

Q = Flow rate H = Total manometric head

Tolerance of characteristic curves in compliance with EN ISO 9906 App. A.

POS.	COMPONENT	CONSTRUCTION CHARACTERISTICS			
1	PUMP BODY	Cast iron, with threaded port in compliance with ISO 228/1			
2	BASE	Stainless steel AISI 304			
3	IMPELLER	Stainless steel AISI 304 DOUBLE-CHANNEL type			
4	MOTOR CASING	Cast iron			
5	MOTOR CASING PLATE	Stainless steel AISI 304			
6	MOTOR SHAFT	Stainless steel EN 10088-3 - 1.4104			
7	SHAFT WITH DOUBLE SEAL AND OIL CHAMBER				
	<i>Seal</i>	<i>Shaft</i>	<i>Materials</i>		
	<i>Model</i>	<i>Diameter</i>	<i>Stationary ring</i>	<i>Rotational ring</i>	<i>Elastomer</i>
	MG1-14 SIC	Ø 14 mm	Ceramic	Silicon carbide	NBR
8	LIP SEAL	Ø 15 x Ø 24 x H 5 mm for MC 10/45 Ø 16 x Ø 24 x H 5 mm for MC 15/45			
9	BEARINGS	6203 ZZ / 6203 ZZ			
10	CAPACITOR				
	<i>Pump</i>	<i>Capacitance</i>			
	<i>Single-phase</i>	<i>(230 V or 240 V)</i>	<i>(110 V)</i>		
	MCm 10/45	20 µF 450 VL	30 µF 250 VL		
	MCm 15/45	25 µF 450 VL	-		
11	ELECTRIC MOTOR				
	- Single-phase 230 V - 50 Hz with thermal overload protector built-in to the winding - Three-phase 400 V - 50 Hz - Insulation: F class - Protection: IP 68				
12	POWER CABLE				
	10 metre long "H07 RN-F" cable (with Schuko plug on single-phase versions only)				
13	FLOAT SWITCH (only for single-phase versions)				

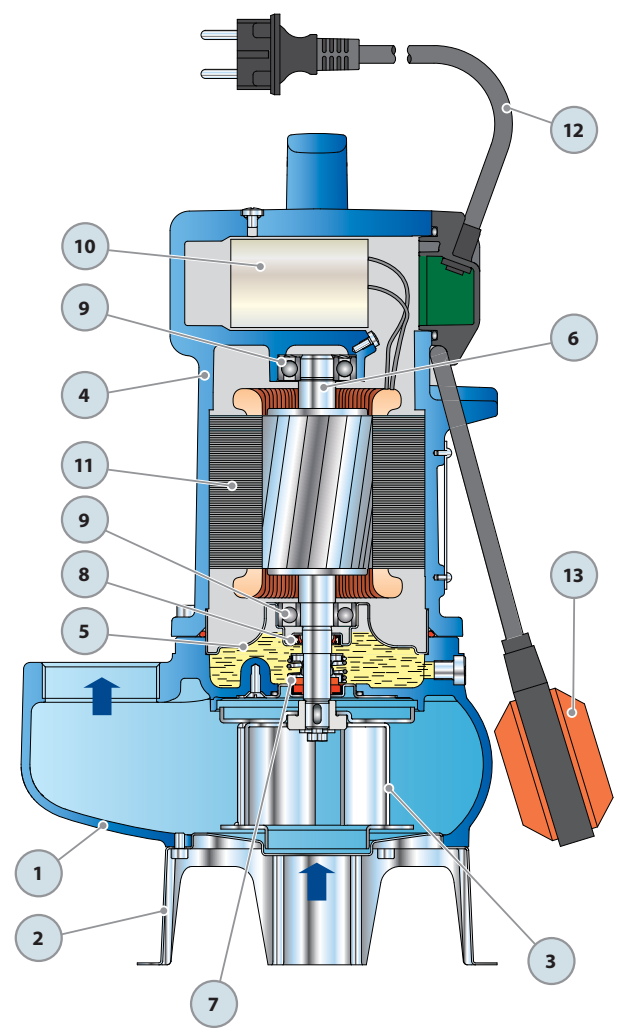

DIMENSIONS AND WEIGHT

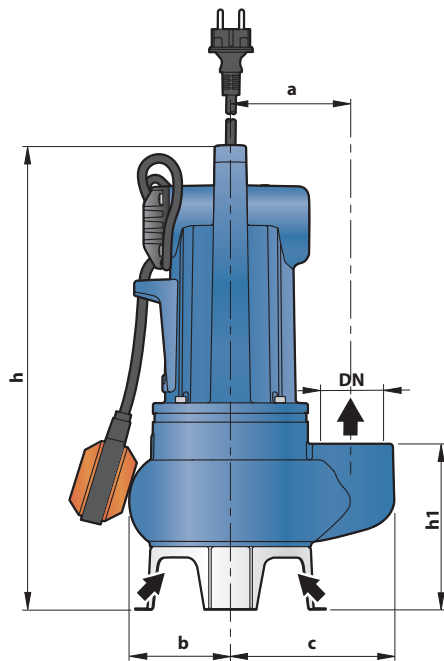

Typical installation

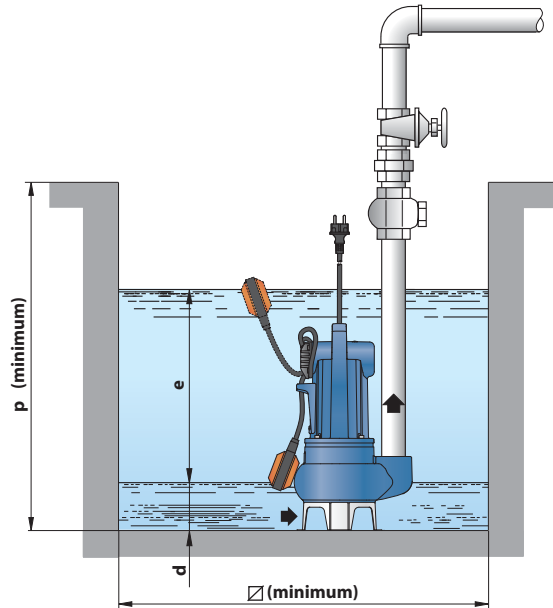

MODEL		PORT DN	solids passage	DIMENSIONS mm									kg	
Single-phase	Three-phase			a	b	c	h	h1	d	e	p	Ø	1~	3~
MCm 10/45	MC 10/45	2"	Ø 50 mm	110	92	150	414	153	60	variable	500	500	20.8	19.2
MCm 15/45	MC 15/45			115	97	157	435	159					23.7	21.8

ABSORPTION

MODEL	VOLTAGE (single-phase)		
	230 V	240 V	110 V
MCm 10/45	5.2 A	5.2 A	11.5 A
MCm 15/45	8.5 A	8.5 A	-

MODEL	VOLTAGE (three-phase)			
	230 V	400 V	240 V	415 V
MC 10/45	3.6 A	2.1 A	3.6 A	2.1 A
MC 15/45	6.1 A	3.5 A	6.1 A	3.5 A

PALLETIZATION

MODEL		GROUPAGE			CONTAINER				
Single-phase	Three-phase	n° pumps	H (mm)	kg		n° pumps	H (mm)	kg	
				1~	3~			1~	3~
MCm 10/45	MC 10/45	45	1400	953	881	60	1820	1265	1169
MCm 15/45	MC 15/45	45	1574	1085	998	60	2052	1441	1325

